

Interfacing TFT LCD Display Modules to MCU STC12LE5A60S2

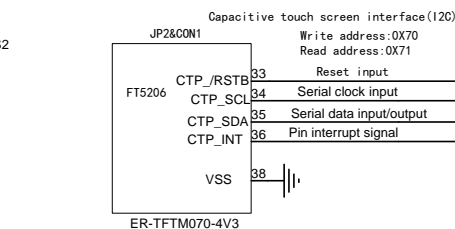

NOTE: IF Without TP, Pin33 to Pin38 is NC
TE pin use description please refer to the SSD1963 data sheet

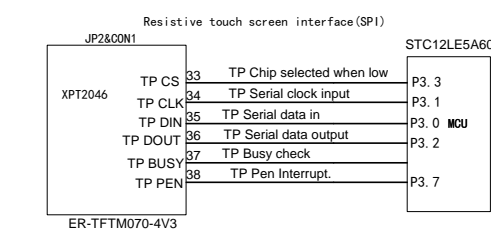
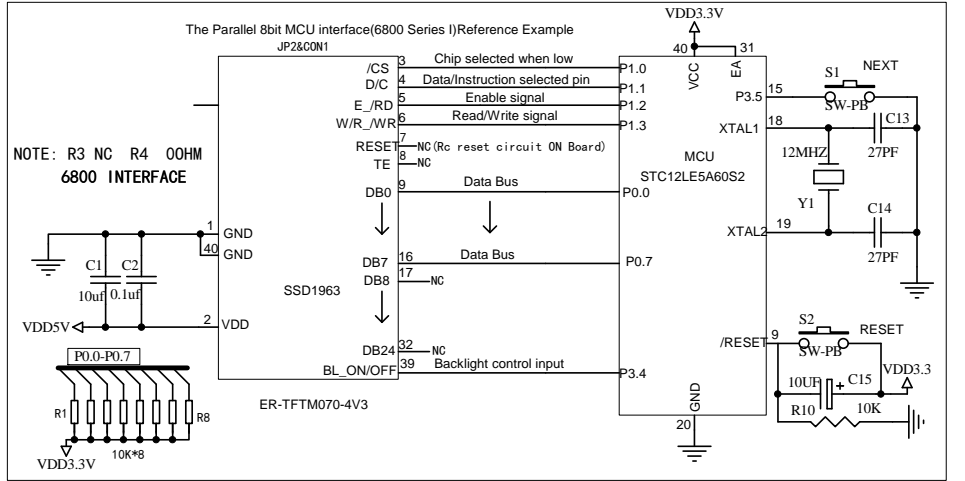
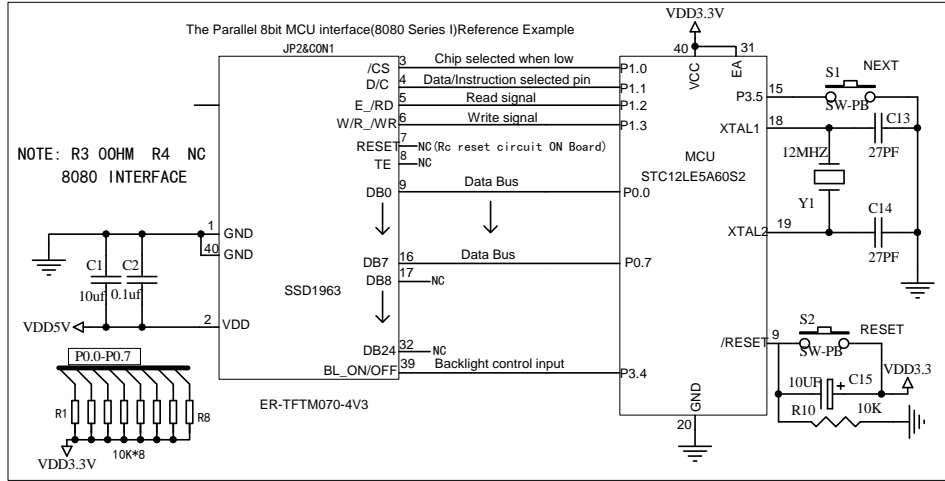
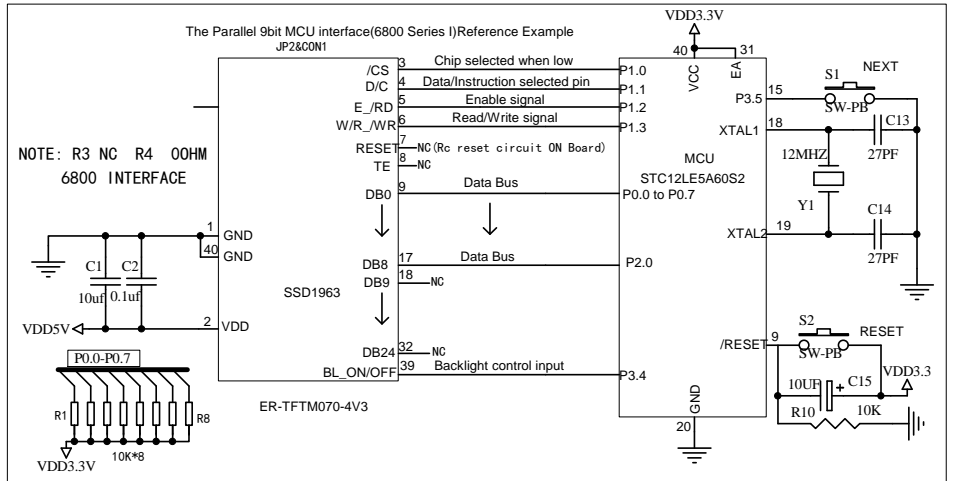
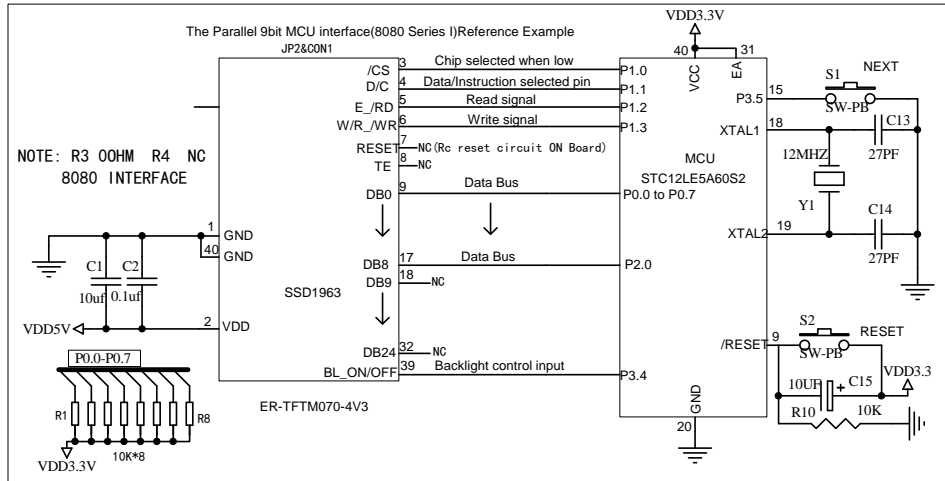
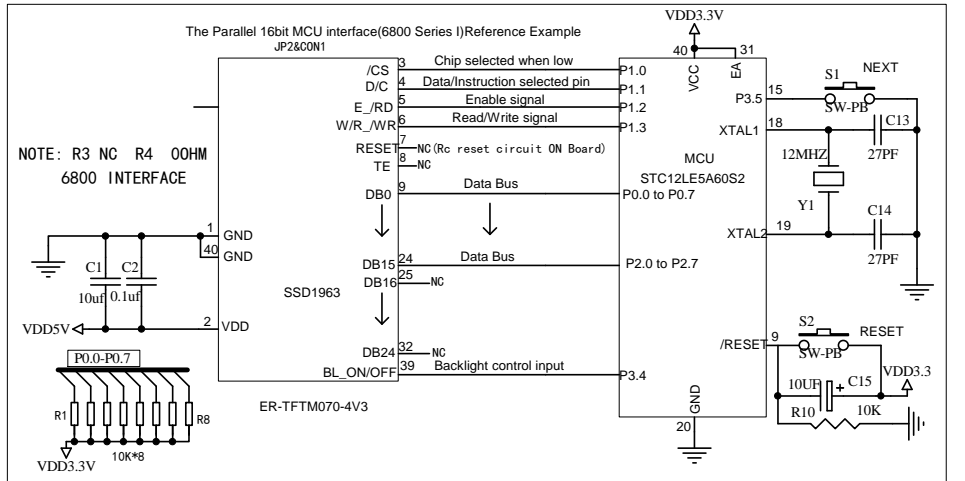
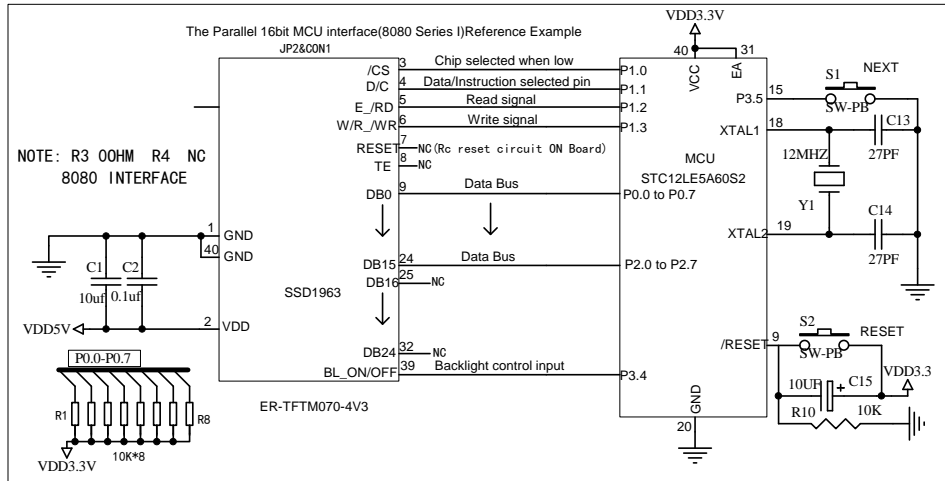
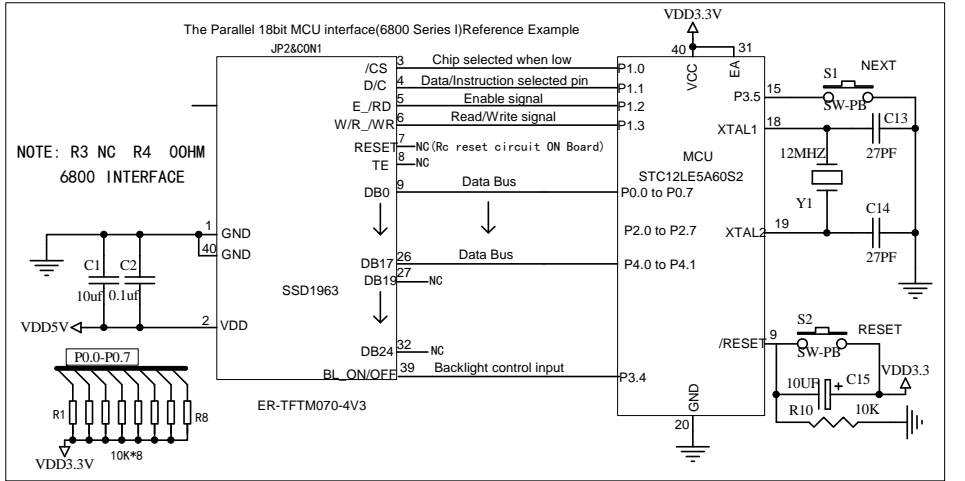
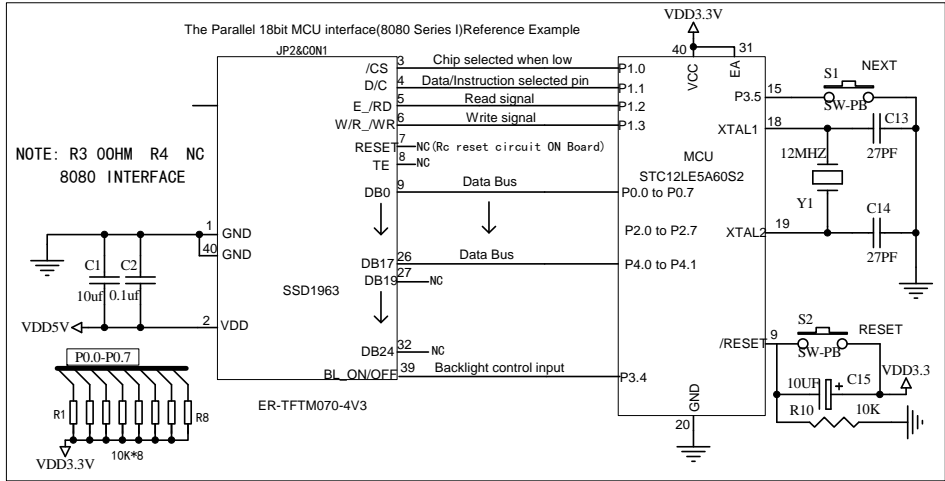
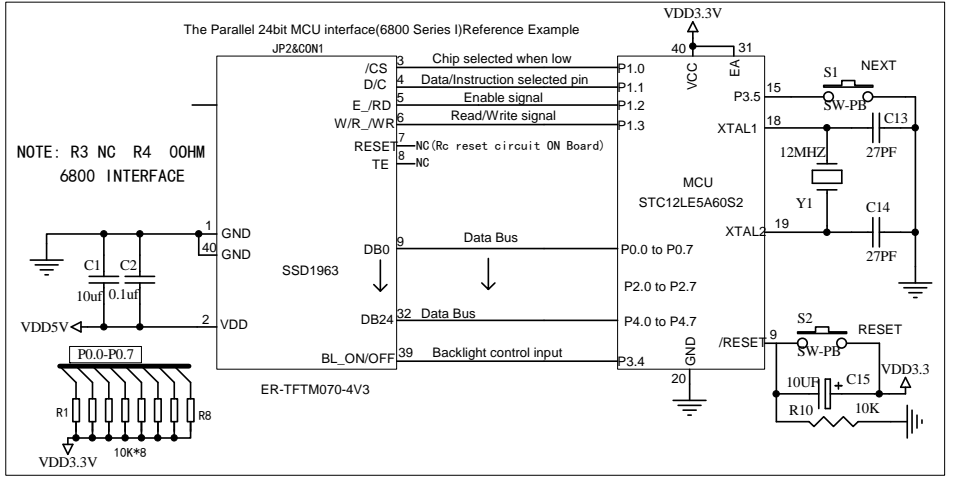
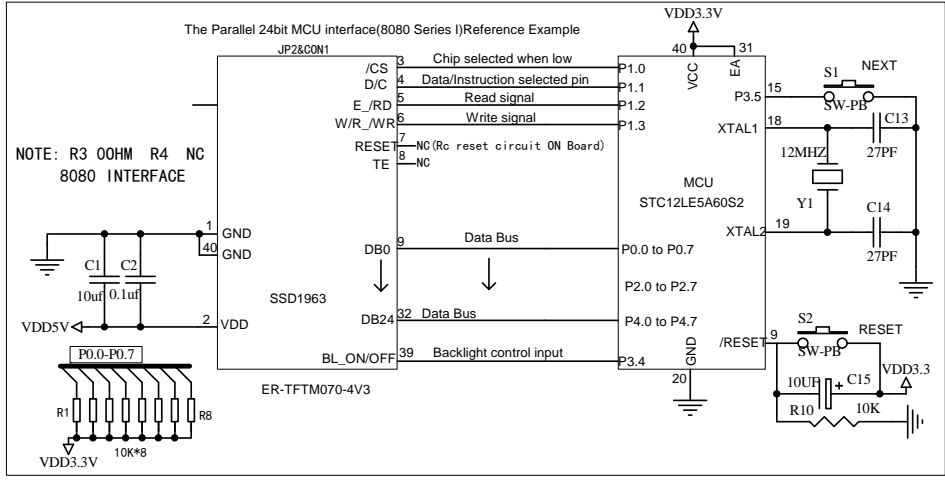
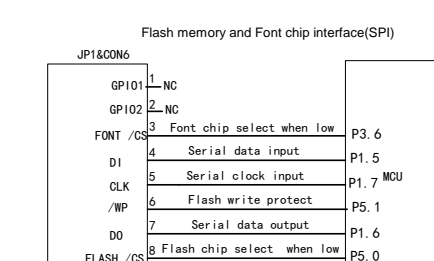
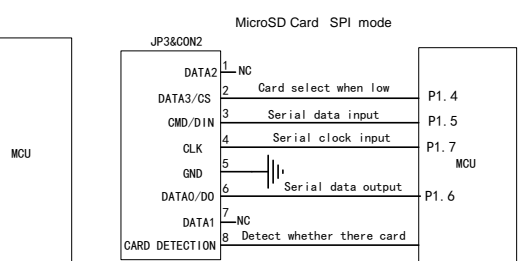
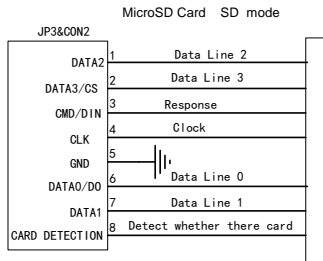

REV.	DESCRIPTION OF MODIFY	MODIFY BY	DATE
A0	1'ST DESIGN	JIM	Nov-29-2013
A1	2'ND DESIGN	JIM	DEC/28/2015

Title EASTRISING TECHNOLOGY CO.,LTD.			
Size A	Number ER-TFTM070-4V3	Revision A1	
Date: Jun-11-2024	Sheet of 1		Drawn By Javen